

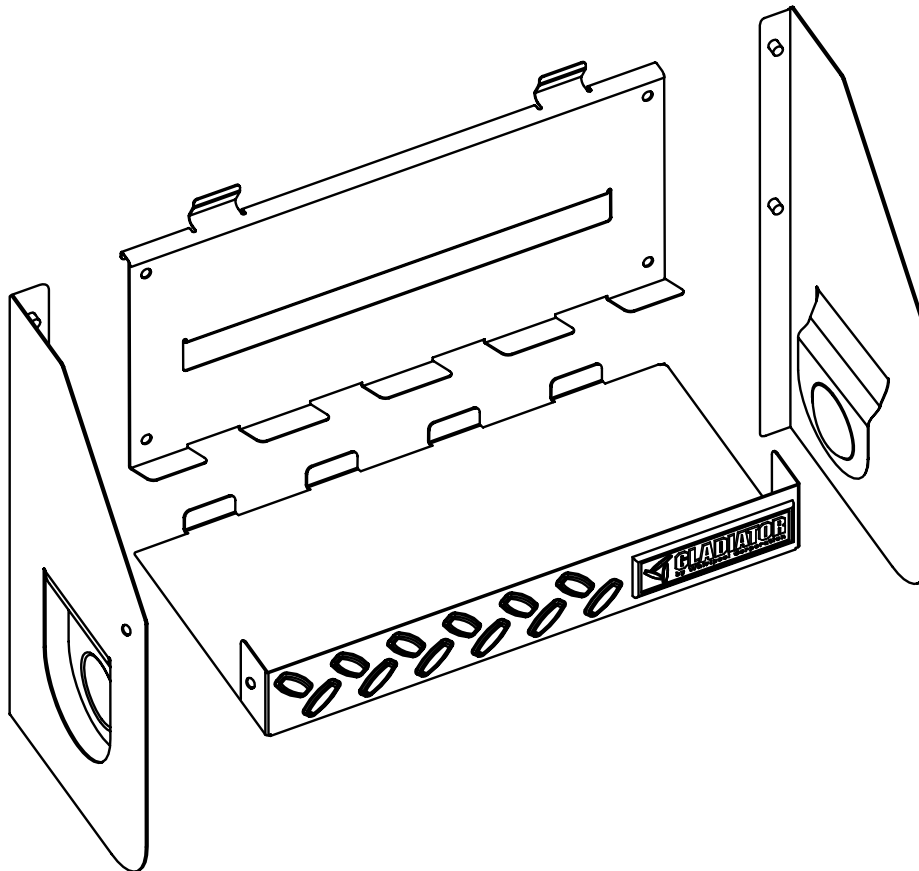

**CLEAN UP CADDY**  
Assembly Instructions

**CLEAN UP CADDY**  
Installationsanvisning

**CASIER À ACCESSOIRES  
POUR NETTOYAGE**  
Instructions d'assemblage



**IT'S TIME TO RETHINK THE GARAGE.®**  
**LE GARAGE REPENSÉ.™**

**W10128646A**

In U.S.A. call: 1-866-342-4089  
En EE.UU. llame al: 1-866-342-4089  
Aux É.-U. téléphoner au 1-866-342-4089

In Canada call: 1-800-807-6777  
En Canadá llame al: 1-800-807-6777  
Au Canada téléphoner au 1-800-807-6777

[www.GladiatorGW.com](http://www.GladiatorGW.com)  
[www.gladiatorgarageworks.ca](http://www.gladiatorgarageworks.ca)

# INSTALLATION INSTRUCTIONS

## Clean Up Caddy Use Requirements

- Intended to be installed on Gladiator® Garageworks GearWall® panels or GearTrack® channels.
- Maximum weight limit is 25 lbs (11.4 kg)

## Unpack the Clean Up Caddy Parts

Remove the caddy parts and fasteners, and dispose of/recycle all packaging materials.

## Assemble Clean Up Caddy



F3b



F10

F3b Phillips-head screw (2) F10 Acorn nut (6)

Gather the required tools before starting assembly.

### Tools Needed:

- 3/8" Nut driver
- Phillips screwdriver

1. Insert the threaded studs at the top of each side piece into the two holes in each side of the caddy back.  
**NOTE:** Make sure the bracket rim on the caddy back is to the outside of the side pieces.
2. Using two acorn nuts (F10) per side, attach the sides to the back. Completely tighten with a 3/8" nut driver.

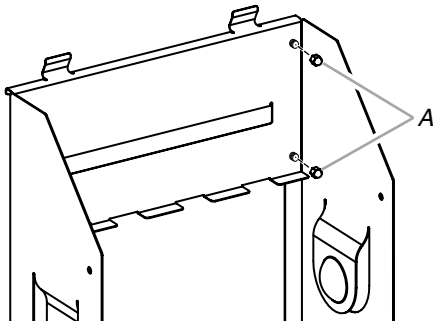

A. Acorn nuts (F10)

3. Attach the caddy shelf (with the name badge facing up) by interlocking the shelf tabs with the tabs on the back.  
**NOTE:** The tabs on the caddy back fit underneath the tabs on the caddy shelf.

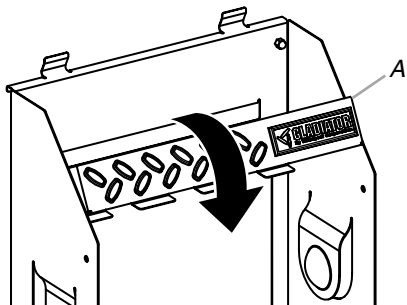

A. Bottom piece

4. Using the two Phillips-head screws (F3b) and two acorn nuts (F10) fasten the caddy shelf to the sides.

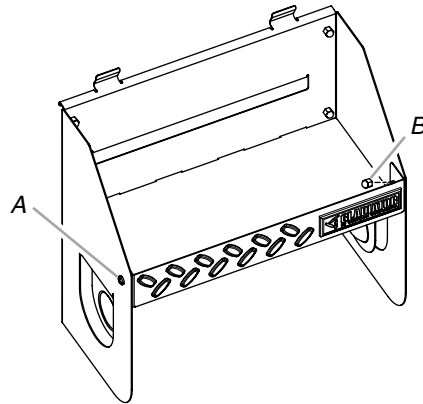

A. Phillips-head screw (F3b)  
B. Acorn nut (F10)

5. Holding each screw in place with a screwdriver, completely tighten the acorn nut with the nut driver.

## Mount the Clean Up Caddy to the Wall

**IMPORTANT:** Be sure the GearWall® panels or GearTrack® channels are installed with mounting screws in every slot and at every stud location with a maximum of 24" (60.96 cm) horizontally between screws.

1. Engage the bracket rims located on the back of the caddy into the slots in the GearWall® panel or GearTrack® channel by lifting up, pushing toward the wall and lowering the rims into the slots.
2. Inspect the caddy from the side to ensure the bracket rims are fully engaged in the slots as shown.

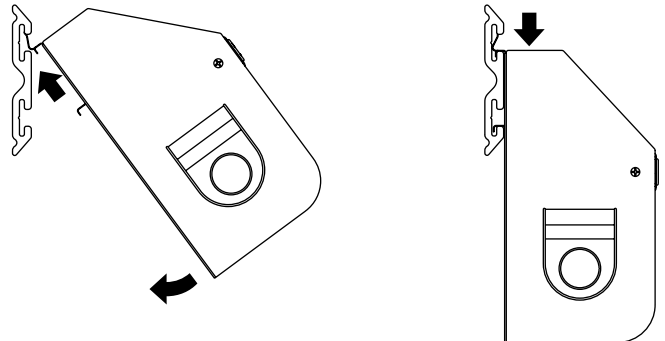

## Warranty

For warranty information:

In Europe call +46(0)21-134410 or visit our website at [www.gladiatorgarage.se](http://www.gladiatorgarage.se)



